



UAS4STEM

DRONE ENGINEERING CHALLENGE



2026 ADVANCED DIVISION RULEBOOK

VERSION 2.2



SUPPORTED BY



UAS4STEM



ADVANCED AWARDS*

(per team)

1st place: \$2500

2nd place: \$2000

3rd place: \$1500

BEGINNER AWARDS*

(per team)

1st place: \$1250

2nd place: \$1000

3rd place: \$750

The Dewey O. Broberg Jr. award* is presented by competition judges to recognize a student who shows dedication to their team, determination, and adherence to the rules and purpose of the competition. \$500

The Gardner Chambliss award* is presented to a team manager who exemplifies the spirit of mentorship, dedication, and care. The award is based on nominations from students, parents, and co-managers via an online form. Nominations are due by August 7, 2026. Visit this QR code for more information!



BEGINNER DIVISION:

Basic search mission
No payload pickup or delivery

ALL DIVISIONS:

Ground school completion
Student video creation
Flight readiness review
Virtual preliminaries
International competition

ADVANCED DIVISION:

Advanced search mission
Design and fabrication of
mission-specific mechanism

How to choose a competition division:

All new UAS4STEM teams are highly encouraged to choose the beginner division. UAS4STEM teams who have placed first, second, or third at finals within the past two years must select the advanced division.

If a team feels that there are extenuating circumstances in regard to preferred division, reach out to the UAS4STEM competition staff.

SUPPORTED BY



5161 E. Memorial Dr., Muncie IN 47302
modelaircraft.org

UAS4STEM.ORG

If you have questions about the UAS4STEM program, please contact the Education Department at education@modelaircraft.org, or (765) 287-1256

*Award amounts may be adjusted.

This Rulebook is the exclusive intellectual property of the Academy of Model Aeronautics (AMA). AMA grants you a limited license to use this guide only in connection with official UAS4STEM events. All other uses are expressly prohibited without AMA's written authorization. You may not modify, copy, prepare derivative works, publicly display, distribute, or remove any copyright or other proprietary notations in this rulebook. Any use of this rulebook for commercial purposes without AMA's permission is strictly prohibited. To request authorization to use this rulebook for any other purpose, or if you have questions about permissible uses, contact AMA at amauas4stem@modelaircraft.org.

TEAM RULEBOOK

1. CONCEPT OF OPERATIONS

Your team has been contracted to inspect a faulty tower to determine any defects. Your drone must conduct a waypoint navigation mission while complying with special instructions (SPINS) that will inform you of how to operate in the area. These SPINS are provided prior to the start of the mission. Your drone must remain within the assigned operational area. Based on the inspection, you will retrieve the appropriate equipment (using an engineered mechanism affixed to the drone that you design) and deliver it to the stationary target. There is a moving vehicle that is en route to the tower. Unfortunately the driver forgot their hat. You may choose to deliver their hat.

2. INTRODUCTION

UAS4STEM provides participants with the knowledge and practical experience to conduct safe, efficient, and effective drone operations. The competition develops professional skills such as teamwork, time management, critical thinking, and so much more.

2.1 COMPETITION DIVISIONS

UAS4STEM teams who have competed in the previous two seasons of UAS4STEM and have placed in the top three are required to compete in the advanced division. *If a team feels that there are extenuating circumstances in regard to the preferred division, reach out to the UAS4STEM competition staff.*

2.2. OPPORTUNITIES AND RECOGNITION

Student teams are judged based on their performance and that of their system. Awards and recognition are given for top performances. Opportunities for interaction with aviation professionals and industry leadership are provided.

2.3. RULES

The competition is based upon the rules outlined within this document containing administrative and performance objectives. UAS4STEM staff reserves the right to make changes to these rules and issue clarifications, updates, or addendums at any time.

3. SCHEDULE

See www.uas4stem.org or refer to UAS4STEM communications for updated scheduling information.

4. MAJOR ELEMENTS OF THE COMPETITION

4.1. REGISTRATION PROCESS

Once the team manager sends all requested team information and pays the registration fee, memberships are distributed for one team manager, one assistant manager, and up to ten student team members aged 11-19. Credentials for the virtual ground school will then be created.

4.1.1. Only registered UAS4STEM participants (not to exceed ten students per team) are allowed to compete or participate in scored competition activities.

4.1.2. It is required that all student members of the team who are competing successfully complete the virtual UAS4STEM Ground School course. Failing to do so will result in team disqualification.

4.1.3. All participants should comply with any national and local regulations regarding model aircraft and the national airspace.

4.1.4. By participating in the competition, the team, advisors, all support members, as well as judges and volunteers, agree to have any pictures of persons, vehicles, or equipment photographed and released to the public.

4.1.5. Once a team has officially entered ten





SAMPLE MAP

Red outline: No-fly-zone boundary
 Blue outline: Waypoint sequence
 Green outline: Search area
 White star: Designated take/off and landing area
 White circle: Payload delivery search area

students on their roster, any changes to the roster that result in new members may be assessed an additional fee.

4.1.6. Use of AI to develop SPINS Mission Planner commands during judged competition activities is prohibited.

4.2. VIRTUAL PRELIMINARY COMPETITION

The virtual preliminary competition occurs in the spring. Each team has the opportunity to schedule an appointment slot with the judges; UAS4STEM communications contain information about this process. Appointments are in Eastern Time, with flexibility offered across time zones. These last approximately 50 minutes total. Presentations should be conducted in the order provided in the Competition Scoring Guide.

4.2.1. Prior to the competition, a proof-of-flight video shall be submitted to verify that the team's aircraft can fly in a safe manner. This is a pre-requisite for possible advancement to the championship. The aircraft should be in full autonomous configuration and perform the following: 1) Take off. 2) Fly to at least one waypoint a minimum distance of 75 feet from launch. 3) Return to launch for landing. The proof-of-flight video shall be less than 3 minutes in length, identify the school and the team name, shall show the ground control station screen, and aircraft flight. A link to this

video posted as a private video on the internet (YouTube is preferred) shall be submitted to the UAS4STEM staff prior to the virtual preliminary competition.

4.2.2. The team will present a Flight Readiness Review (FRR). Teams may provide visual aids (slide deck) as a part of the FRR. Scoring is based upon the scoring guide.

4.2.2.1. The FRR is a primarily live presentation during which the teams substantiate, with data, their plans to safely accomplish the mission. Ensure all technical information is easy for non-UAS professionals to understand.

4.2.2.2. The FRR shall not exceed 20 minutes in duration.

4.2.3. Other scored components: A 15 minute ArduPilot Mission Planner software assessment to program the UAS mission based on provided SPINS. The points available are referenced in the scoring guide.

4.3 CHAMPIONSHIP COMPETITION (FINALS)

This competition is in-person and attendance is by invitation only, extended to the highest scoring teams from the virtual preliminary competition. There is no advancement fee to participate in the finals to teams who are invited. Teams are responsible for all associated travel costs. Any changes from the preliminary competition requirements are outlined below. The finals consist of two separately scored elements, the FRR presentation and the flight mission. A competition schedule will be made available.

4.4. FRR PRESENTATION

The FRR is a scored element worth 30% of the score.

4.4.1. Teams may use their aircraft or ground control station for the FRR. Teams will have access to digital displays to present slides/video. Teams may not power on the aircraft. Only one electronic device, laptop, or tablet may be used for FRR.

4.4.2. Developmental Test Results parameter now worth (25 points)

4.4.3. Evidence of Mission Accomplishments now worth (15points)

4.4.4. Pre-Mission Briefing now worth (15points)

4.4.5. Conduct now worth (10points)

4.4.6. Representatives from other competing teams are not allowed to view presentations of competitors during the event.

4.4.7. Presentations may be recorded and made available for public viewing after the competition.



UAS4STEM PRELIMINARY COMPETITION SCORING GUIDE

Advanced Division (100 points* available)

FRR Presentation (maximum 20 minutes)

PARAMETER	OBJECTIVE (Points are based on depth of content provided.)	POINTS
TEAM MEMBER INTRODUCTIONS	Introduction of all team members. Including flight mission roles and experience. All team members present are encouraged to fully participate.	Mission roles = 0-2 pts Experience = 0-2 pts Participation = 0-1 pts
VIDEO PRESENTATION	A student-produced video should be shown during the FRR. The video shall creatively showcase the UAS4STEM competition and team, offering insight, tips, tricks, or support for new teams. Video should exhibit technical prowess, quality of content, and creativity. The video shall not exceed 3 minutes in length and must be shown during FRR presentation for points. Please send a link to the team's video (YouTube is preferred) to UAS4STEM staff via email.	Technical = 0-3 points Content = 0-4 points Creativity = 0-3 points
SYSTEM OVERVIEW	Identify flight tasks planned, expected performance, and any risk evaluation.	Tasks = 0-3 pts Performance = 0-3 pts Risk eval. = 0-4 pts
SYSTEM SAFETY	Identify design and operational strategies based around safety.	Design = 0-5 pts Operational = 0-5 pts
DEVELOPMENTAL TEST RESULTS	Include test plan schedule (include ground testing, flight testing, and mission performance testing), results of testing, and any corrective action taken to improve the effectiveness of mission completion.	Plan = 0-5 pts* Results = 0-5 pts* Corrective = 0-5 pts*
EVIDENCE OF MISSION ACCOMPLISHMENTS	Show the judges what you have achieved. This evidence should be focused on the requirements delineated in section 1. These may include charts, graphs, images, short video clips, flight logs, etc.	0-10 points *
PRE-MISSION BRIEFING	Include personnel resourcing for the flight mission, communication procedures, and go/no-go criteria.	Personnel = 0-3pts* Comms. = 0-3 pts* Go / No-Go = 0-4 pts*

Other Components (maximum 15 minutes)

PARAMETER	OBJECTIVE	POINTS
MISSION PLANNER SOFTWARE ASSESSMENT	Teams will be presented with a mock mission. Teams must have Ardupilot Mission Planner software loaded onto the computer they are using for the virtual FRR presentation and must share their screen with the judges. Teams have 15 minutes to program the mission planning software to achieve the mission objective. Failure to correctly execute command(s) will nullify the current and subsequent commands and the scoring will stop. Consider factors such as "automated take-off" and the setting of a home point as prerequisites to a successful mission. A judge will time this portion of the challenge, may provide a 2-minute warning, and will stop assessment as needed.	0-25 points *

PARAMETER	OBJECTIVE	POINTS
CONDUCT	Aspects such as professionalism, teamwork, and communication will be factored into the score. This applies to the entire session.	0-5 points *

*Indicates these values are adjusted for the final competition.

In order to compete, each team member must successfully pass UAS4STEM ground school. In the case of a tie, team average ground school scores will be utilized to determine placement. Allowances for technical difficulties that may arise during virtual competitions will be at the discretion of the judges.

FLIGHT OPERATIONS SCORING GUIDE



PARAMETER	OBJECTIVE	POINTS
INITIAL AUTONOMOUS TAKEOFF	To receive points on the first takeoff attempt, teams must achieve a controlled autonomous takeoff. Takeoff is complete when drone reaches an altitude > or = 100 ft. and hovers for a minimum of 5 seconds. Team must initiate the takeoff. Takeoff must take place within the designated takeoff and landing area.	Failure to meet objective = 0 points Autonomous takeoff = 4 points Maximum 4 points
WAYPOINT NAVIGATION	SPINS will be provided at the beginning of the flight operations. Teams must execute waypoints and commands in sequence based on the SPINS. Waypoints and commands will not be within 30 ft. of any "no-fly-zone" boundary. While in autopilot control waypoints must be accurate to within 25 ft accuracy, and maintain navigation within 50 ft. along the planned flight path. Any mission planner command may be utilized. Failure to complete previous command line will nullify subsequent commands/points. Team must announce to the judges which waypoint and command is being attempted. During this objective, teams may be able to identify the location of POI's (see 6.3.) so long as the SPINS are not interrupted. Flight operations outside of assigned tasks (takeoff, landing, pickup, delivery, or inspection/reading QR codes) must maintain an altitude of >=50 feet.	Each successful command line = 2 point Maximum points = 16
INITIAL AUTONOMOUS LANDING	To receive points for this parameter, on the first landing attempt, teams must achieve a successful controlled autonomous landing. Team must initiate the landing. Landing must take place within the designated takeoff and landing area.	Failure to meet objective = 0 points Autonomous landing = 4 points Maximum 4 points
INSPECTION MISSION/PAYLOAD IDENTIFICATION	The inspection tower is described in "Tower Build Guide" section. Search the tower to locate a 7"x7" defect icon, shown in "Defect Icons" table. This icon will direct you to the correct payload. Retrieve and deliver that payload to the stationary target. Team must provide visual evidence to a judge of what defect icon they see in order to continue with retrieval and delivery.	Correct defect icon ID = 5 points Maximum 5 points
PAYLOAD PICKUP & PAYLOAD DELIVERY	Teams may descend to 0 altitude for this portion of the competition. Only intact and unmolested payloads will be scored. To score, deliveries must be initiated, not accidental. To score, pickup of correct payload must achieve at least 5 ft. altitude above target. Payloads are identified in section 6. MOVING TARGET (3' x 3' with 1" lip at edges of target): Teams will be provided an EAA AeroEducate hat at setup time. Use the drone to deliver this hat to the moving target. Officials will stop the movement of the target at the completion of the delivery attempt (when the drone reaches a minimum of 20' altitude post-delivery). Movement of the target is triggered at the start of this objective. The correct payload must be selected to score.	STATIONARY TARGET: 0 ft. to 2 ft. = 10 points 2 ft. to 4 ft. = 8 points 4 ft. to 6 ft. = 6 points 6 ft. to 8 ft. = 4 points 8 ft. to 10 ft. = 2 points MOVING TARGET: Payload misses target = 0 points Payload lands on target and remains = 15 points Maximum 25 points
AUTONOMY	Between one and ten points are awarded at judge's discretion as to the level of autonomy incorporated by teams for the following elements: each POI pickup and delivery target identification, the tower and defect identification (combined), pickup attempt, hammer delivery attempt, and hat delivery attempt. Fully manual operations score = 0. Automated waypoint search grid with manual pause and modification of flight path = 5. Fully automated search grid and identification and modification of flight path to identify and register locations of POIs = 10 for each section.	Tower/Inspection ID = 0-10 points POI Ballpeen = 0-10 points POI CLAW = 0-10 points POI Moving Target = 0-10 POI Stationary Target = 0-10 Payload pickup = 0-10 points Hammer delivery = 0-10 points Hat delivery = 0-10 points Maximum of 80 points
OVERALL SAFETY SCORE	Between zero and ten points are awarded at judge's discretion as to the safety considerations incorporated by teams.	Maximum of 10 points

POINT OF INTEREST GRAPHICS (printed at 3'x3')



POI: TOWER



POI: MOVING-TARGET

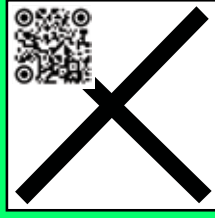

POI: STATIONARY-TARGET



POI: BALLPEEN-HAMMER



POI: CLAW-HAMMER

DEFECT ICONS (printed at 7"x7")



ID: BENT-METAL-BALLPEEN



ID: BENT-NAIL-CLAW

4.4.8. Presentations should be conducted in the order provided in the Competition Scoring Guide

4.5. PRE-FLIGHT SAFETY INSPECTIONS

All UAS are subject to a safety inspection by designated officials. Safety inspections may include a physical inspection, a fail-safe check, and flight termination check.

4.5.1. The safety inspections are not a scored element. All decisions of the safety inspector(s) shall be final.

4.5.2. Physical inspection of the aircraft may include:

4.5.2.1. Verify all components are adequately secured to vehicle.

4.5.2.2. Verify rotor structural attachment integrity.

4.5.2.3. Visual inspection of all electronic wiring.

4.5.2.4. Verification of fail-safe mode operation covered by manual override and pilot-commanded flight termination.

4.5.3. If teams make any hardware changes to their UAS, a new proof-of-flight video is required prior to final competition.

4.5.4. The GCS shall provide sufficient information to operators on a continuous basis to ensure that it is operating within no-fly/altitude boundaries.

4.5.4.1. The aircraft shall be capable of manual override by the safety pilot during all flight operations.

4.5.4.2. The flight termination system (kill switch), activated by a single switch, shall be capable of overriding all flight modes to terminate the flight.

4.5.4.3. The aircraft shall automatically Return-to-Launch (RTL) then land after loss of primary communications link signal within 5 seconds.

4.6. FLIGHT MISSION REQUIREMENTS

The flight mission evaluates the teams' ability to conduct a mission with their vehicle. This is worth 70% of the competition score.

4.6.1. Team must attend the daily safety brief on the day of their scheduled flight operations. Anyone conducting flight operations on this day must be present and on time. **Failure to do so may incur up to a 20% penalty to the team's overall score.**

4.6.2. A lead judge is assigned to each team at the flight line. It is important that all team members follow the instructions of the judges. There may be additional judges assigned who are focused on different aspects of the competition (imagery, autonomy, safety, teamwork, maintaining visual line of site, etc.) depending on which tasks the team is planning to accomplish.

4.6.3. Only systems presented in the FRR, available for inspection by designated official(s), and included in the proof of flight video are permitted to fly.

4.6.3.1 In order to compete, each team member must successfully pass UAS4STEM ground school.

4.6.3.2 In the case of a tie, team average ground school scores are utilized to determine placement.

4.7 OPERATIONAL TIMELINE

Time management/safety = efficiency. Make the most of this time to ensure you can accomplish the mission objectives.

4.7.1. Setup time = 15 minutes maximum. This

begins when the team arrives at the flight line. A judge is assigned to each team and will start a timer after communicating with the team. After the fifteen setup minutes have elapsed, the flight timer will start regardless of the team's readiness to launch the mission.

4.7.2. Flying Time = 30 minutes maximum.

4.7.2.1. Flying time shall start at the declaration by the judge who will have a timer. TEAMS MUST KEEP THEIR OWN TIME. ONCE ON THE CLOCK, A TEAM MAY NOT ASK NON-STUDENT TEAM MEMBERS FOR REMAINING TIME. If flight is still being conducted past the 30 minute mark, judges will announce the termination of the mission and direct the team as to the correct landing procedure.

4.7.2.2. A team may elect to cycle through the takeoff and landing sequence during the flying time more than once (change batteries, payload, etc). No points are lost, but flying time continues to be used.

4.7.2.3. Flying time stops when the vehicle has completed flight (landed, crashed, or terminated) and the team has disconnected flight battery. Judge will confirm with the team that the flying time has stopped.

4.7.2.4. The system shall be swiftly disassembled and transported off of the flight line after the flying time has stopped.

4.8 MISSION LIMITATIONS

Aircraft shall remain in controlled flight and within the no-fly-zone boundary.

4.8.1. A specific no-fly-zone boundary description will be provided to teams prior to conducting the flight mission.

4.8.1.1. Any vehicle appearing uncontrolled or moving beyond the no-fly-zone boundary during autonomous flight is subject to immediate manual override. Failure of manual override will result in flight termination.

4.8.1.2. Maximum flight altitude is 200 ft. AGL unless otherwise specified.

4.8.2. Takeoff shall take place within the designated takeoff/ landing area.

4.8.2.1. Only the first takeoff attempt is eligible for autonomy points. Taking off under manual control is permitted. Takeoff under manual control with transition to autonomous flight is permitted but does not count as an autonomous takeoff.

4.8.3. Landing shall take place within the

designated takeoff/landing area.

4.8.3.1. Only the first landing attempt is eligible for autonomy points. Landing under manual control is permitted.

5. APPROVED COMPONENTS

The only off-the-shelf sUAS allowed to be flown for scored UAS4STEM elements are related to the pre-recorded video presentation element. As a training aid, pre-manufactured aircraft may be utilized.

5.1 LAPTOP GUIDELINES

Each team must provide their own laptop computer. Only a single laptop is allowed on the flight line and with the team during the FRR presentation. One additional monitor may be used on the flight line. This monitor may only display information from the computer. Example. You may duplicate a display on a laptop, or this can be the primary display for a desktop. It may not display video from the aircraft. Teams will need to purchase UAS components that comply with provided specifications (see appendix for additional detail).

5.2. PROVIDED EQUIPMENT

Teams are provided shade, a folding table, chairs and a single electrical power extension cord. Teams should plan to provide their own power strip, if required.

6. ADDITIONAL FLIGHT OPERATIONS DETAIL

The flight mission has been divided into a series of parameters. Teams do not need to complete every parameter unless the parameter is a requirement. The available parameters are listed in the flight operations scoring guide.

6.1. PAYLOAD DELIVERY SPECIFICATIONS

6.1.1. Payload delivery mechanism must be designed and built by team members. No commercially available payload mechanisms allowed.

6.1.2. If the payload delivery mechanism must be powered, it must use the primary battery source.

6.1.3. Payload delivery mechanism(s) may be removable and installed as needed.

6.1.4 No portion of the payload delivery mechanism may remain attached to payloads after delivery.

6.1.5. Payload details:

6.1.5.1. Both ["claw"](#) and ["ball peen"](#) hammers are available for purchase from Harbor Freight. These are both 8oz hammers, with a total height of ~6.5".

6.1.5.2. The hat to be delivered to the moving target is the ["EAA Hat Sunny Bucket"](#) PLU:

6.2 GROUND CONTROL STATION (GCS) DISPLAY

Teams must accurately display current aircraft position. GCS must also display airspeed and altitude to operators and judges. This is a minimum requirement for flight approval.

6.3 POINTS OF INTEREST

Five POIs (3'x3') are in the flight area. One POI is an inspection target identified within your SPINS. Two POIs are pickup targets. One POI is a stationary delivery target. One of these POIs is a moving delivery target.

6.3.1. The moving target is an RC vehicle pulling a 3'x3' target. This vehicle is traveling <5 mph and operating in a set continuous circuit. The movement of the target is initiated when a team communicates their intention to begin delivery of the moving target payload to a judge.

7. SAFETY REQUIREMENTS

7.1. FLIGHT OPERATIONS

7.1.1. Flight operations of any type involve some level of risk to personnel and property. It is the responsibility of all personnel involved in and around flight operations to identify, evaluate, and mitigate risks to the maximum extent possible.

7.1.2. When teams are conducting flight tests, extra precautions must be in place to protect team members and others.

7.1.3. It is recommended that teams use an experienced RC pilot to act as their safety pilot for test flights. The safety pilot for competition flights must be a student team member.

7.2. OTHER

7.2.1. Up to 10 student team members are allowed in the mission area. Team managers shall not participate. Anyone may observe from designated area.

7.2.2. Closed toe shoes are required to be worn during safety inspections, flight line operations, or when rotors are powered. Anyone wearing open-toed shoes will not be allowed to participate in any activity on the flight line.

7.2.3. Officials have the right to disqualify an individual or a team for any reason.

- side of an arm to the other)
- Additional processors are allowed, but must cost less than \$315 USD.
- Autopilot system must cost less than \$750 USD Manufacture Suggested Retail Price (MSRP), including the Global Positioning System (GPS)
 - o This is a retail cost, meaning that even if a more expensive autopilot is donated, it is not allowed.
 - o It does not have to be a Pixhawk variant, but Pixhawk is recommended
- Maximum of 8 channels
 - o These include 4 for the motors, leaving four open to be utilized as the team sees fit
- Options include a camera gimbal, pickup, and drop mechanism controls
- If you use 2 for the gimbal, that leaves only 2 channels for pickup and drop mechanism(s)
- Maximum 4S 5200 battery size (any "C" rating) Batteries may be changed as often as necessary during the competition
- Recommended propeller size 11"
- Up to a 1080p video camera
 - o Camera Manufacturer's Suggested Retail Price (MSRP), must be less than \$125 USD
- Digital video is allowed
 - o Camera and receiver Manufacturer's Suggested Retail Price (MSRP), must be less than \$400 USD combined
- Up to a 250mw video transmitter
- Any antenna may be used for the video feed system
- 2.4 Ghz RC control system. Any brand legal in the US
- One primary Ground Control Station (GCS) – Meaning only 1 laptop allowed on the flight line
- Maximum of 2 video receivers allowed during the competition
 - o One can attach directly to the GCS
- Recommended telemetry radio RFD 900+
- One additional sensor may be utilized. Sensor must be less than \$70 USD MSRP.

DRONE COMPONENT SOLUTIONS

You may purchase any component that meets the requirements of the specifications within this rulebook. To purchase pre-packaged compliant drone components for UAS4STEM, visit www.quadzilladrone.com or www.readymaderc.com to learn more about available options. If there are any questions about an airframe or components, please contact UAS4STEM Technical Director Archie Stafford at archie@modelaircraft.org

APPENDIX

AIRFRAME SPECIFICATIONS

- Quadcopter configuration (4 motors)
- 650mm maximum frame size (measured from one

.UAS4STEM CODE OF CONDUCT

The UAS4STEM Code of Conduct is designed to ensure that all participants contribute to a safe, respectful, and productive environment during all UAS4STEM activities. By participating in UAS4STEM, you acknowledge your understanding of these expectations and agree to follow the rules outlined below. Failure to follow the Code of Conduct may result in disciplinary or legal action to include removal from the event and/or future competitions.

1. UAS4STEM is a safe and respectful environment. Participants should act as positive role models, demonstrating leadership, and teamwork. Treat everyone with kindness and respect.
2. UAS4STEM has a zero-tolerance policy for any harassment or abuse. If you see something inappropriate or concerning, it is your responsibility to report it to UAS4STEM leadership and/or a trusted adult.
3. All participants should dress safely for the event. This includes, but is not limited to, wearing closed-toe shoes and other safety gear as required.
4. Treat all property, equipment, and personal belongings with care and respect.
5. The use of alcohol, drugs, e-cigarettes, or tobacco products is prohibited at any official UAS4STEM event activity.

UAS4STEM EVENT GUIDELINES

1. UAS4STEM is a safe and respectful environment. All participants shall model appropriate behavior and lead by example. UAS4STEM has a zero-tolerance policy for any harassment or abuse.
2. If you witness or are the victim of harassment or abuse, immediately report it to a trusted adult and/or UAS4STEM staff. If you believe anyone is in immediate danger, contact law enforcement immediately.
3. Drugs, alcohol, e-cigarettes, and tobacco products are prohibited during official UAS4STEM event activities.
4. During official event activities, you consent to the use of any photographs, videos, or audio recordings of your participation for promotional or educational purposes by UAS4STEM staff.

NOTES

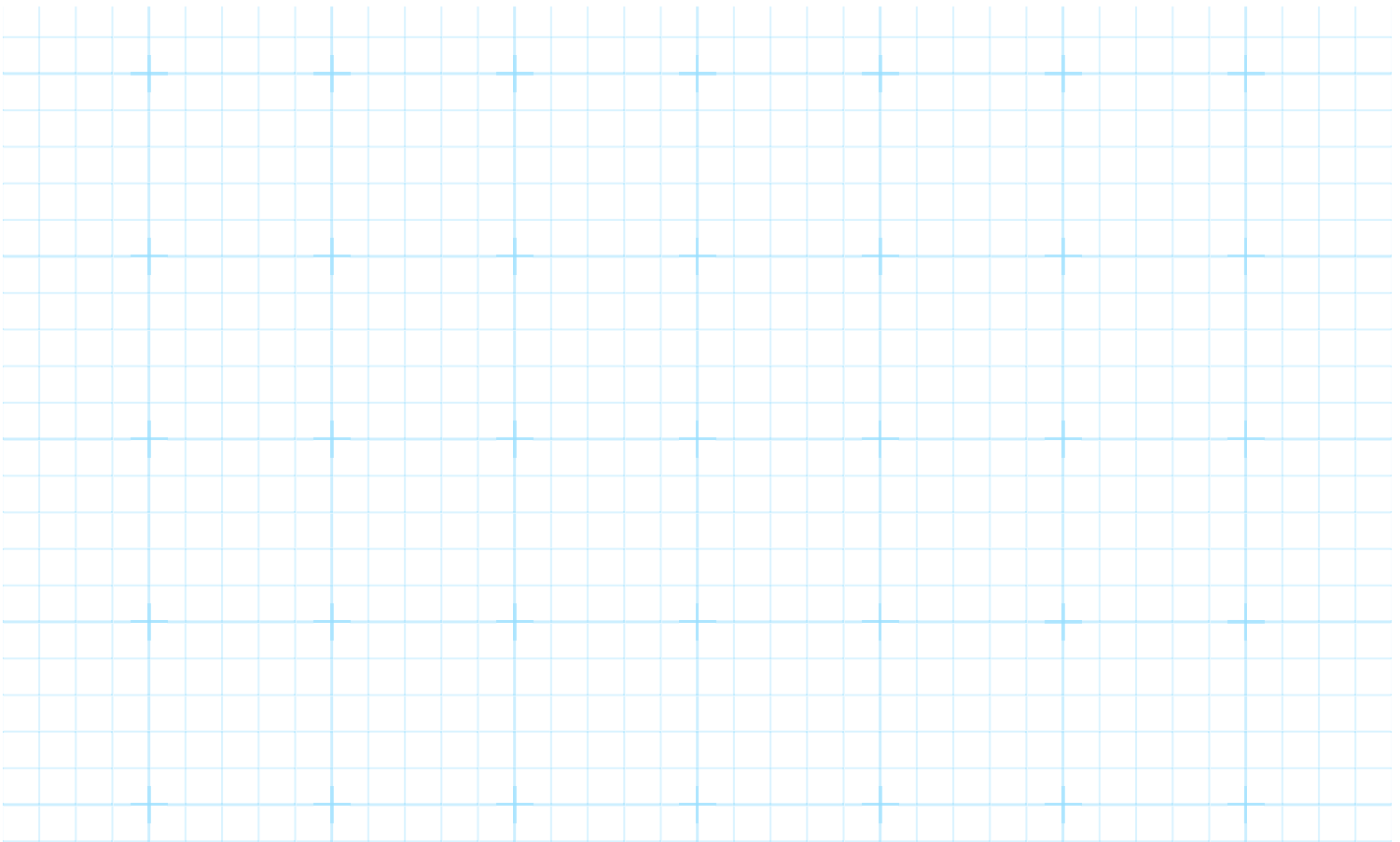
A large grid of light blue lines for taking notes, consisting of 20 columns and 20 rows of small squares.

SAMPLE MISSION SET:

1. Fly to Waypoint 40.171337°, -85.318303° at 90'. Hold for 3 seconds
2. Fly to Waypoint 40.171313°, -85.316926° at previous altitude while pointing the nose of the aircraft at your takeoff point
3. Fly to Waypoint 40.171674°, -85.318312° while climbing to 175' and make the aircraft rotate to face due north upon arrival at waypoint
4. Fly to Waypoint 40.171797°, -85.317044° while descending to 100' and perform 2 circles around the point in either direction
5. Fly to Waypoint 40.171580°, -85.317505° descending to 75' while pointing the nose at the previous waypoint
6. Fly to Waypoint 40.171041°, -85.318218° while climbing to 150' and descend to 50' once at the waypoint
7. Fly to Waypoint 40.171582°, -85.318768° at the previous altitude and rotate the aircraft in either direction 2 turns
8. Fly to Waypoint 40.171242°, -85.317147° while climbing to 100' and stop for 15 seconds

(Solution located below)

TOWER BUILD GUIDE

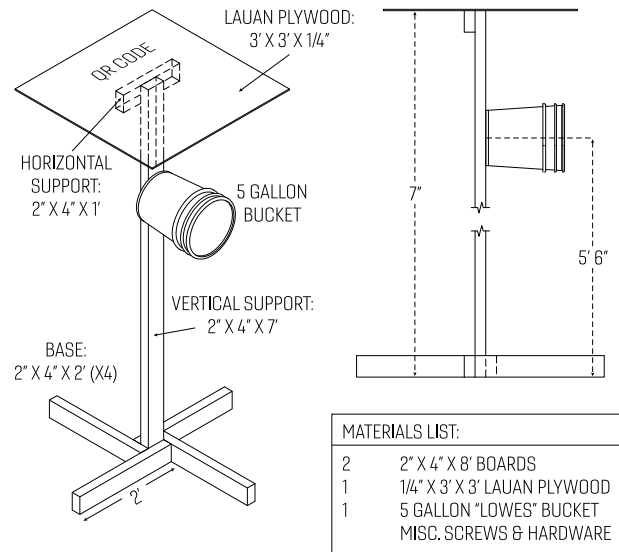

Command	Delay	Lat	Long	Alt	Frame	Delete	Grad	Angle	Dist	AZ
WAYPOINT	3	40.171337	-85.318303	90	Relative	X	25.5	14.3	364.8	308
DO_SET_ROI	0	40.170741...	-85.31729...	0	Relative	X	0	0	0	0
WAYPOINT	0	40.171313	-85.316926	90	Relative	X	38.8	21.2	249.1	26
WAYPOINT	0	40.171674	-85.318312	175	Relative	X	20.8	11.8	416.9	289
CONDITION_YAW	0	0	0	0	Relative	X	0	0	0	0
WAYPOINT	0	40.171797	-85.317044	100	Relative	X	-21.0	-11.9	364.1	83
LOITER_TURNS	2	0	0	5	Relative	X	0	0	0	0
DO_SET_ROI	0	40.171797	-85.317044	0	Relative	X	0	0	0	0
WAYPOINT	0	40.17158	-85.317505	75	Relative	X	49.7	26.4	168.5	238
WAYPOINT	0	40.171041	-85.318218	150	Relative	X	26.8	15.0	289.5	225
WAYPOINT	0	40.171041	-85.318218	50	Relative	X	--	-90.0	100.0	180
WAYPOINT	0	40.171582	-85.318768	50	Relative	X	0.0	0.0	249.9	322
LOITER_TURNS	2	0	0	0	Terrain	X	0	0	0	0
WAYPOINT	15	40.171242	-85.317147	100	Terrain	X	155.6	57.3	866.6	105

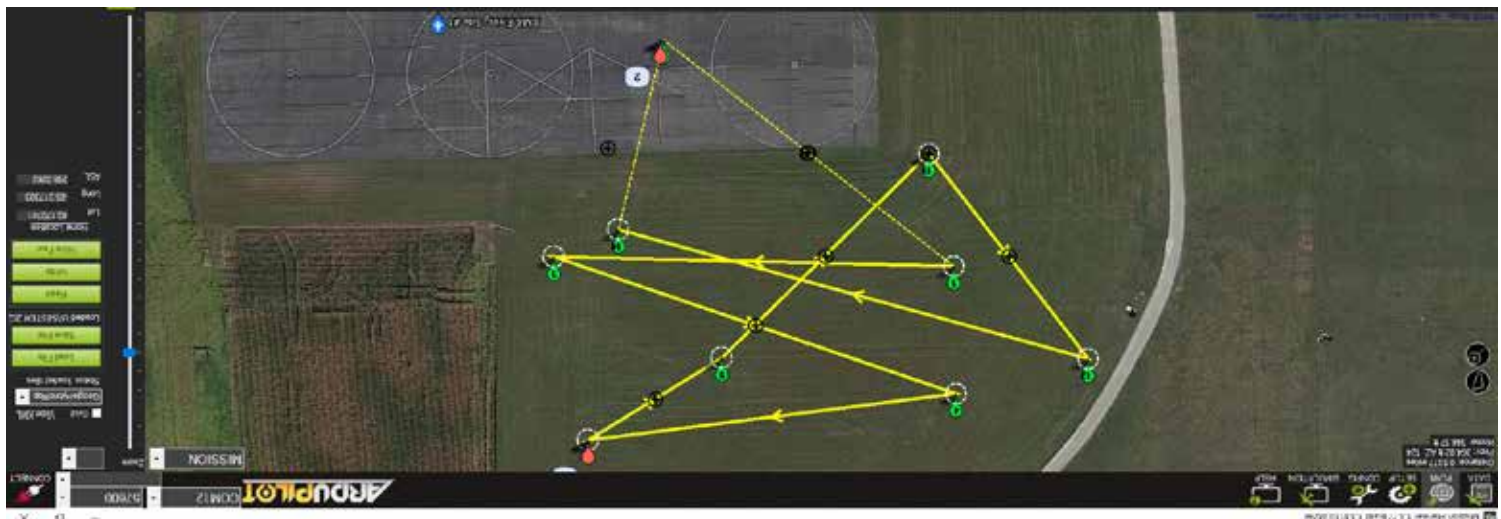



UAS4STEM

DRONE ENGINEERING CHALLENGE

NOT YOUR TYPICAL FLIGHT CLUB



WATCH A VIDEO



SUPPORTED BY SIMNET, EAA THE SPIRIT OF AVIATION, AMA FOUNDATION

WWW.UAS4STEM.ORG